

SRC750

SRC750 ROUGH-TERRAIN CRANE
75 TONS LIFTING CAPACITY

Quality Changes the World

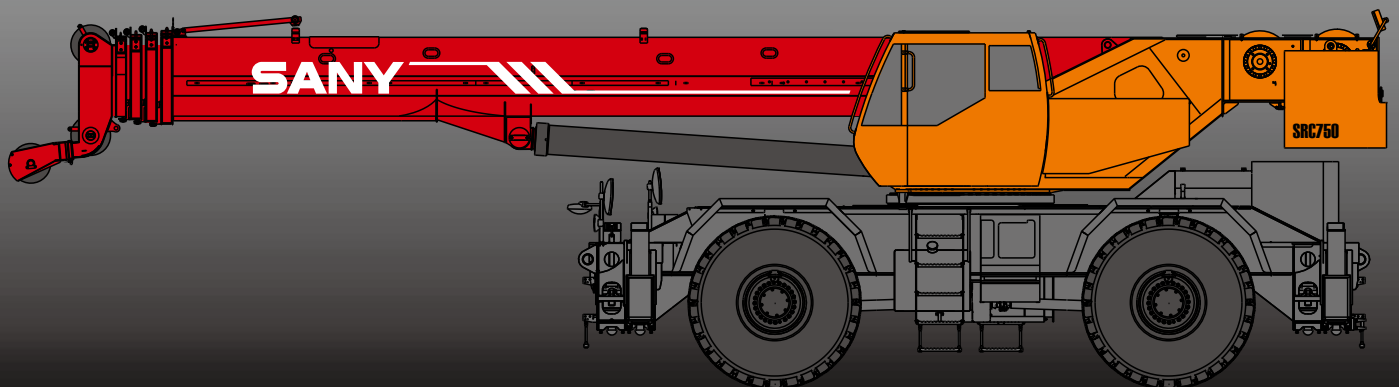

SANY

■ SANY Automobile Hoisting Machinery is one of the core business unit of Sany Heavy Industry, mainly engaged in the research and development of high end, mid to large tonnage crane series, including mobile crane, crawler crane, tower crane and loader crane. It has two industrial parks in Ningxiang and Huzhou, since entering the market, the products of Sany Automobile Hoisting Machinery have received worldwide recognition with advanced technology, lean manufacturing, high reliability and excellent service.



SANY ROUGH-TERRAIN CRANE

CONTENT

- 04 Icon
- 05 Selling Points
- 06 Introduction
- 09 Dimension
- 11 Technical Parameter
- 12 Operation Condition
- 13 Load Chart
- 18 Wheel Crane Family Map



Cab



Carrier frame



Suspension system



Hydraulic system



Outriggers



Telescopic boom



Control system



Engine



Lattice jibs



Telescopic system



Transmission system



Superlift devices



Luffing system



Drive/Steer



Luffing lattice jib



Slewing



Axles



winch mechanism:



Counterweight



Tyres



Safety system



Brakes system



Hoist system



Electrical system



Excellent traveling capacity and high-performance chassis system

Four-wheel drive is applied with full hydraulic power steering system and four steering modes to provide good mobility. Trafficability and comfortableness of the complex road condition is improved thanks to its Min. turning radius less than 7.5m.

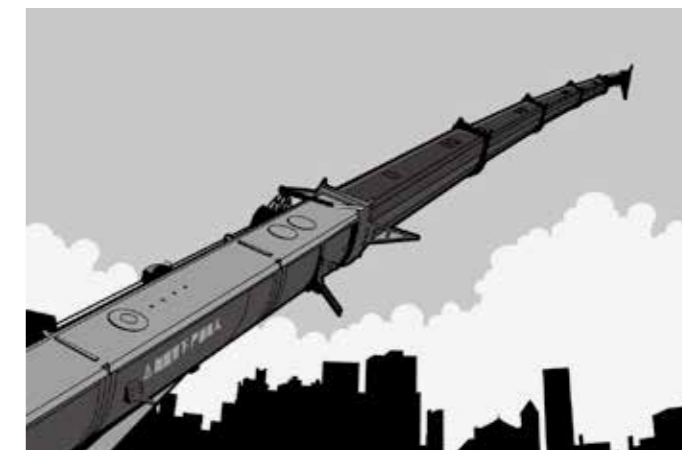

Ultra long and super strong boom system

Five-section boom with high strength steel structure and optimized U-shaped section, reducing weight and improving safety significantly. Jib mounting angles are 0°, 20° and 40°, which ensure fast and convenient change-over between different operating conditions so as to improve working efficiency of the machine.



Highly effective and unique hydraulic system

Hydraulic system load feedback and constant power control is applied to provide strong lifting capacity and good micro-mobility. Unique steering buffer design guarantees smooth braking operation.



Safe and reliable control system

Self-developed controller SYMC specially for engineering machinery is configured. The application of CAN-bus fully digital network control technology ensures stable control signal, simple harness and high reliability. It can feedback the data information and monitor the working condition of whole crane in real-time. Load moment limiter configured with comprehensive intelligent protection system is adopted with precision within 10%. The adoption of comprehensive logic and interlock control system ensures more safe and reliable operation.

Introduction



Cab

- The self-made cab adopts ergonomic design with sliding door, safety glass, anti-corrosion steel, soft interior decoration, large interior space, panoramic sunroof and adjustable seats, air conditioner and electric window wiper etc. to provide easier and more comfortable operation. Load moment limiter display is configured to achieve the combination of main console and operating display system, making all operating condition data of lifting operation clear at a glance.



Hydraulic system

- High-quality key hydraulic components such as main oil pump, rotary pump, main valve, winch motor and balancing parts etc. are adopted to achieve stable and reliable operation of the hydraulic system. Superior operation performance is guaranteed by accurate parameter matching. Through the adoption of load sensitive variable displacement piston pump, pump displacement can be adjusted in real-time, achieving high-precision flow control with no energy loss during operation.
- Main valve has flow compensation and load feedback control function. It significantly enhances control stability for single action and combined action under different operation conditions.
- Winch adopts electronically controlled variable motor, ensuring high operation efficiency. Max. single line speeds of main and auxiliary winches is up to 125m/min;
- Slewing system is equipped with the integrated slewing buffer valve, with free slipping function, ensuring more stable starting and control of the slewing operation and excellent micro-mobility.
- Hydraulic oil tank capacity: 980L.



Control system

- CAN-bus instrument: CAN-bus instrument with a combined intelligent control electrical system is used for easy reading of the traveling parameters at any time. Engine fault warning function enables convenient and fast maintenance.
- With full security protection system, main and auxiliary winches are equipped with over-roll out limiter and height limiters to prevent over-rolling out and over-hoisting of steel rope, tip-over and limit angle protection are included.
- Load moment limiter: The adoption of highly intelligent load moment limiter system can comprehensively protect lifting operation, ensuring accurate, stable and comfort operation.
- The fault diagnosis system can detect superstructure electricity, hydraulic action, chassis (for major safety failure), engine and gearbox for fault to ensure reliable operation of the crane.



Telescopic system

- Five-section boom is applied with basic boom length of 11.8m, full-extended boom length of 45m, jib length of 16m and fully extended boom lifting height of 44.5m respectively. Max. lifting height is 62.5m including jib. It is made of fine grain high-strength steel with U-shaped cross section and with telescopic operation controlled independantly by double cylinder rope.



Luffing system

- Dead-weight luffing provides more stable luffing operation at low energy loss. Dual-action single piston hydraulic pressure cylinder with safety valve is adopted.
- Luffing angle range is $-3^{\circ} \sim 80^{\circ}$.

Introduction



Slewing system

- 360° rotation can be achieved, with Max. slewing speed of 2.0r/min. Hydraulic controlled proportional speed adjustment is applied, providing stable and reliable operation of the system. Unique slewing buffer design ensures more stable braking operation.



Counterweight

- The total weight of fixed counterweight is 9500kg, no flexible counterweight.



Safety system

- Load moment limiter: Load moment limiter calculation system based on lifting load mechanical model is established using an analytical mechanics method, with rated lifting accuracy within 10% through on-line non-load calibration, providing full protection to lifting operation. In case of overload operation, system will automatically issue an alarm to provide safety protection for manipulation.
- Balance valve, overflow valve, and two-way hydraulic lock etc. components are configured for hydraulic system, thus achieving stable and reliable operation of the hydraulic system.
- Main and auxiliary winches are equipped with over roll-out limiter to prevent over rolling-out of wire rope.
- Boom and jib ends are equipped with height limiters respectively to prevent over-hoisting of wire rope.
- Boom head is equipped with anemometer to detect whether the high altitude wind speed is within the allowable range.



Hoist system

- The adoption of pump and motor double variable speed control ensures high efficiency and excellent energy saving functionality. With perfect combination of winch balance valve and unique anti-slip technology, heavy load can be lifted and lowered smoothly. Closed winch brake and winch balance valve effectively prevent imbalance of the hook. High strength, anti-swirl steel wire is equipped for high-precision hoisting positioning.
- Equipped with one 810kg main hook and one 160kg auxiliary hook, and Main and auxiliary hook steel rope diameters are 20mm, the rope length is 245m and 145m respectively.



Carrier frame

- Carrier frame is of box-type structure that is welded with high-strength steel plate, featuring high lifting capacity.

Introduction

- Outriggers**
- H-type outrigger structure and 4-point support is adopted, with Max. span up to 7.52m×7.4m. Featuring easy operation and high stability. Fine grain high strength steel material is adopted and dual-direction hydraulic lock is used for the protection of vertical cylinder of outrigger.
- Engine**
- Type: Inline six-cylinder, water cooled, supercharged and inter-cooling diesel engine
 - Rated power: 210kw/2500r/min
 - Environment-protection: Emission complies with Statelll standard
 - Capacity of fuel tank: 300L
- Transmission system**
- Transmission case: Manual/Automatic transmission case. There are six gears in gearbox. The speed ratio range is large which meets the requirements of low gradeability speed and high traveling speed.
 - Transmission shaft: With optimized arrangement of the transmission shaft, the transmission is stable and reliable.
- Drive/Steer**
- 4×4 drive way and full hydraulic power steering is applied with front wheel steering, rear wheel steering, four-wheel steering and crab traveling modes.
- Axles**
- Front and rear axles are all slewing drive axles.
- Tyres**
- 4*—29.5R25
- Brakes system**
- Double-circuit braking system is adopted, if one circuit fails, the other circuit can ensure normal operation, thus improving the safety and reliability of brake system.
 - Traveling brake: all wheels use the unique slewing brakes and dual-circuit brake system and are equipped with drum brakes.
 - Parking brake is drum brakes equipped on the front axle export flange.
- Electrical system**
- With 24V maintenance-free battery and mechanical power main switch, power of the whole machine can be cut off manually.

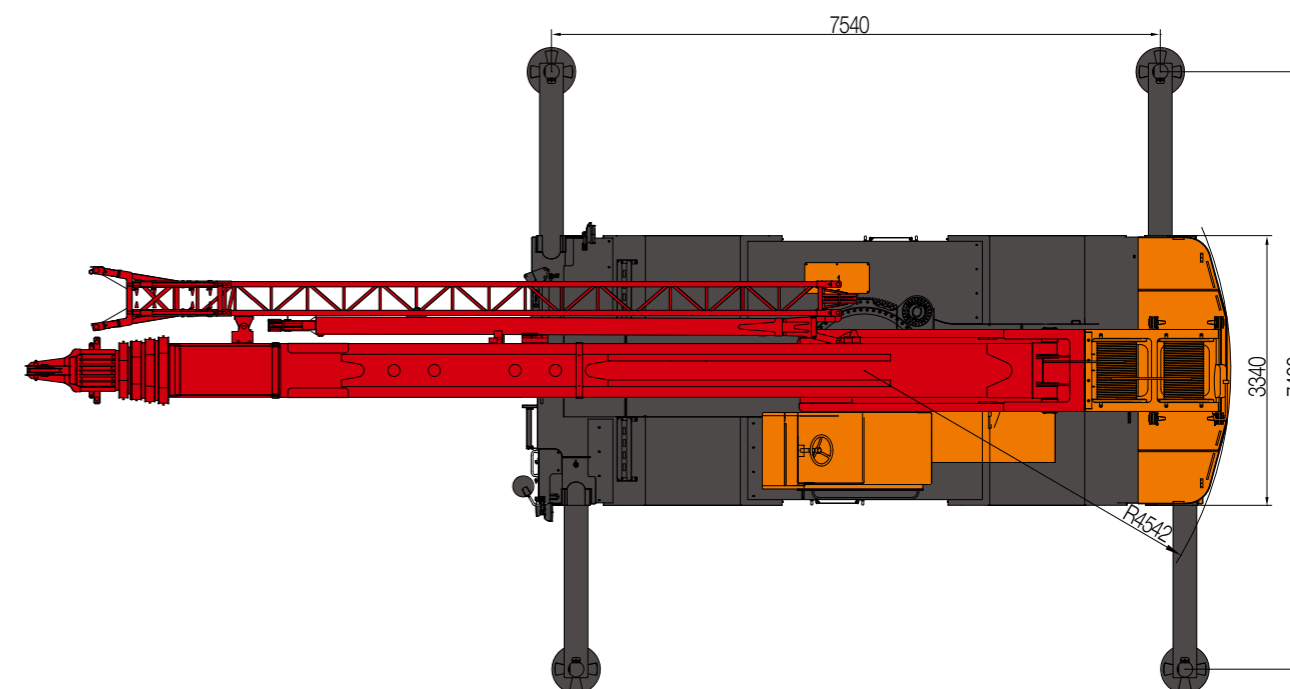
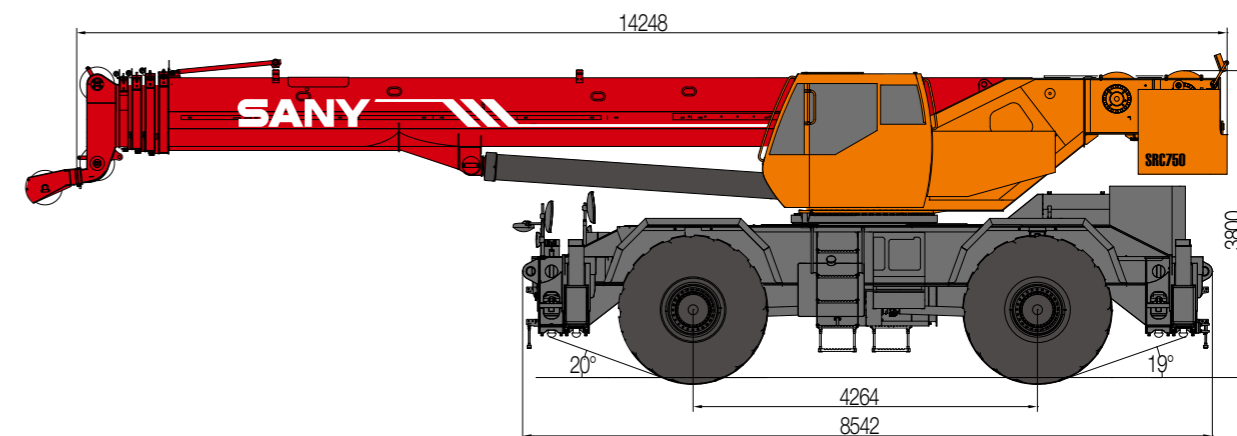

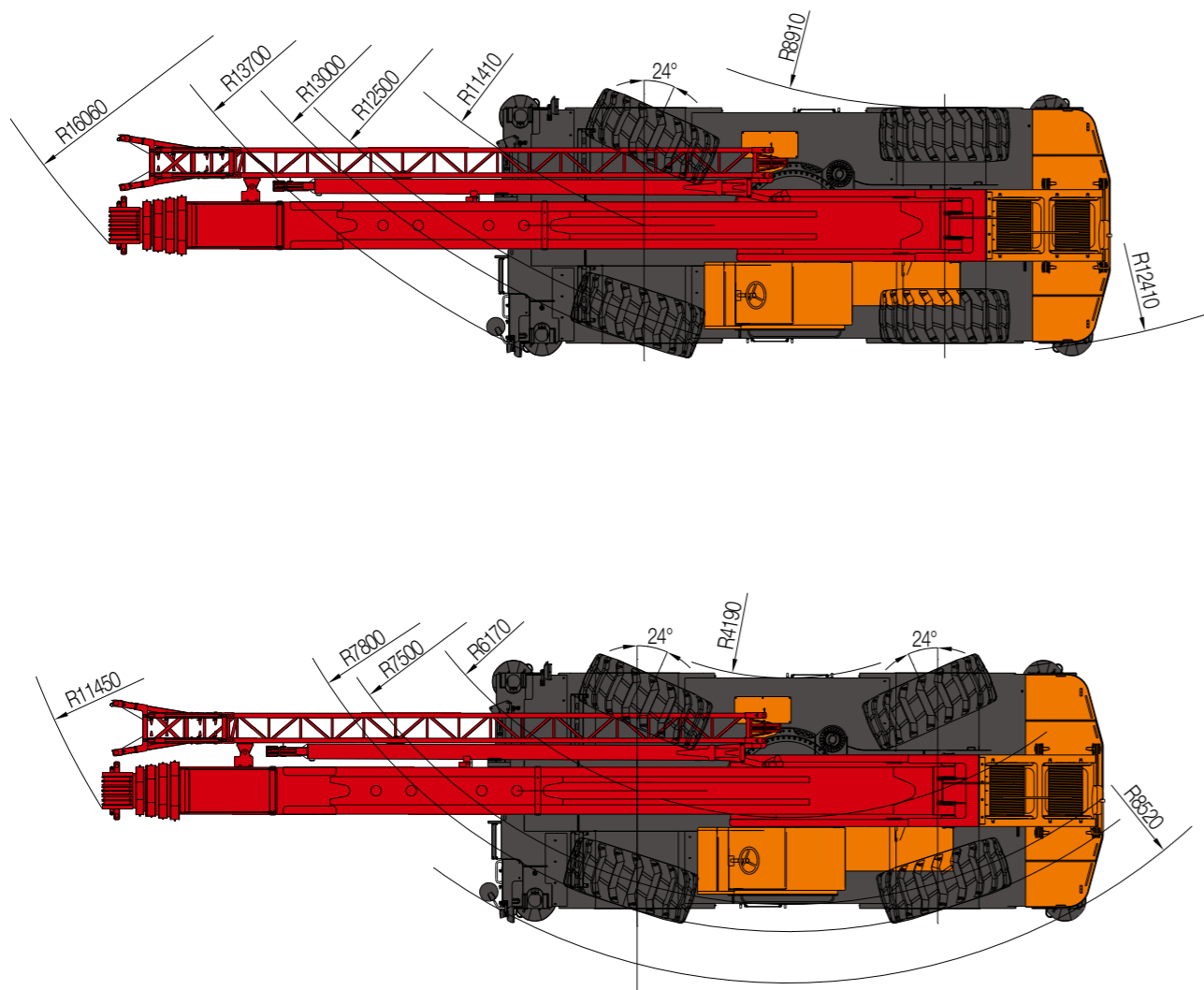

Type	Item	Parameter	
Capacity	Max. lifting capacity	75 t	
Dimensions	Overall length	14280 mm	
	Overall width	3340 mm	
	Overall height	3800 mm	
	Axle distance	4264 mm	
Weight	Overall weight	53400 kg	
	Axle load	Front axle load	27600 kg
		Rear axle load	25800 kg
	Rated power	210 kW/ 2500 rpm	
Rated torque	970 N.m/ 1500 rpm		
Traveling	Max.traveling speed	40 km/h	
	Turning radius	Min.turning radius	12.5 /7.5m
		Wheel formula	4× 4
	Min.ground clearance	400 mm	
	Approach angle	20 °	
	Departure angle	19 °	
	Max.gradeability	75%	
	Fuel consumption per 100km	≤ 70 L	
Main Performance Data	Temperature range	- 20 °C ~ + 46 °C	
	Min.rated range	3 m	
	Tail slewing radius of swingtable	4.543 m	
	Boom section	5	
	Boom shape	U-shaped	
	Max.lifting moment	Base boom	2529 kN·m
		Full-extend boom	1232 kN·m
		Full-extend boom+jib	550 kN·m
	Boom length	Base boom	11.8 m
		Full-extend boom	45 m
		Full-extend boom+jib	61 m
Outrigger span (Longitudinal×Transversal)	7.54 × 7.4 m		
Jib offset	0 °, 20 °, 40 °		
Working speed	Max.single rope lifting speed of main winch (no load)	125 m/min	
	Max.single rope lifting speed of auxiliary winch (no load)	125 m/min	
	Full extension/retraction time of boom	120 / 130 s	
	Full lifting/descending time of boom	70 / 100 s	
	Slewing speed	2 r/min	
Aircondition	Aircondition in cab	Cooling/Heating & Cooling	

SRC750 Working Ranges

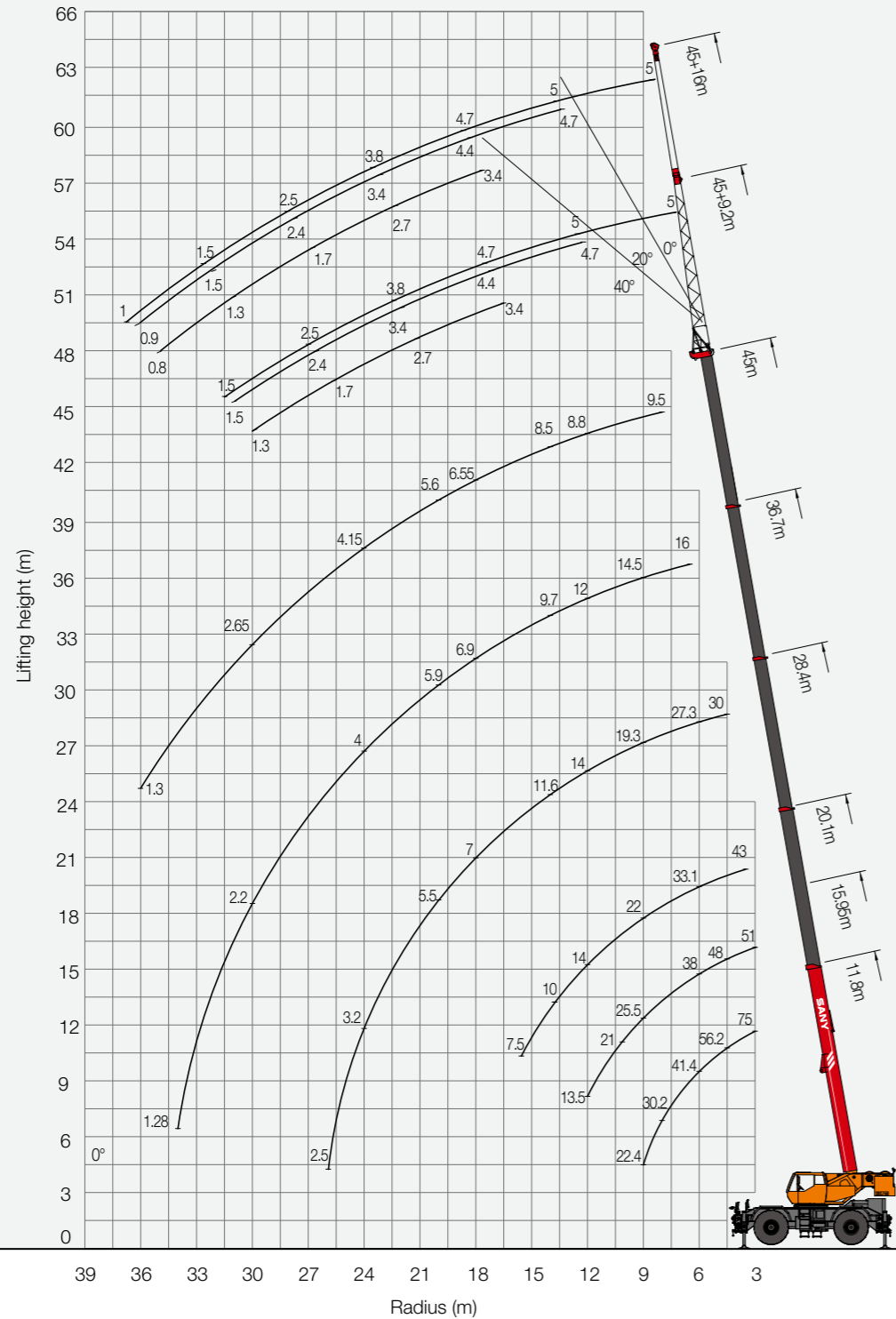

- Prerequisites:**
- ① Boom operating conditions (fully extended boom length), min. length is 11.8m and max. length is 45m
 - ② The span of outriggers is 7.52m x 7.4m
 - ③ 360° rotation is applied
 - ④ Counterweight is 9.5T

Working range(m)	Main boom							Working range(m)
	11.8m	15.95m	20.1m	28.4m	36.7m	40.85m	45m	
3	75000	51000						3
3.5	72000	51000	43000					3.5
4	63000	51000	43000					4
4.5	56200	48000	40500	30000				4.5
5	50400	45000	38000	30000				5
5.5	45500	42000	35400	28500				5.5
6	41400	38000	33100	27300				6
6.5	38000	35500	31000	26000	16000			6.5
7	35000	33000	28500	24600	16000	9500		7
8	30200	28900	25000	22000	15000	9500	9500	8
9	22400	25500	22000	19300	14500	9500	9500	9
10		21000	19700	17300	13900	9500	9200	10
11		17500	17000	15500	13000	9500	9000	11
12		13500	14000	14000	12000	9500	8800	12
14			10000	11600	9700	9300	8500	14
16			7500	9000	8100	7800	7700	16
18				7000	6900	6600	6550	18
20				5500	5900	5650	5600	20
22				4200	5000	4850	4800	22
24				3200	4000	4150	4150	24
26				2500	3000	3600	3600	26
28					2500	3100	3110	28
30					2200	2400	2650	30
32						1700	2000	32
34						1280	1550	34
36							1200	36
Min.elevation angle(°)	/	/	/	/	/	/	30	Min.elevation angle(°)
Number of parts of line	12	9	9	6	4	4	3	Number of parts of line

Prerequisites:

- ① Boom operating conditions(fully extended boom length),min. length is 11.8m and max.length is 45m
- ② The span of outriggers is 7.52m×5.25m
- ③ 360°rotation is applied
- ④ Counterweight is 9.5T

Working range(m)	Main boom							Working range(m)
	11.8m	15.95m	20.1m	28.4m	36.7m	40.85m	45m	
3	70000	51000	0	0	0			3
3.5	65000	51000	43000	0	0			3.5
4	60000	51000	43000	0	0			4
4.5	52000	48000	40500	30000	0			4.5
5	45000	40000	38000	30000	0			5
5.5	38000	34000	31000	28500	0			5.5
6	32000	29300	27000	27300	0			6
6.5	27400	26000	23800	26000	16000			6.5
7	24000	23000	21000	22000	16000	9500		7
8	18500	17500	17000	17000	15000	9500	9500	8
9	14400	14000	13500	14000	13800	9500	9500	9
10	0	11200	10800	11800	12000	9500	9200	10
11	0	9200	8900	10200	10300	9500	9000	11
12	0	7700	7300	8800	9000	9500	8800	12
14	0	0	4900	6300	7000	7400	7000	14
16	0	0	3200	4600	5200	5600	5500	16
18	0	0	0	3300	3900	4300	4200	18
20	0	0	0	2300	2900	3300	3100	20
22	0	0	0	1500	2100	2500	2200	22
24	0	0	0	0	1500	1800	1600	24
26	0	0	0	0	1000	1300	1100	26
Min.elevation angle(°)	/	/	/	/	35.5	39.7	43.7	Min.elevation angle(°)
Number of parts of line	12	9	9	6	4	4	3	Number of parts of line

Prerequisites:

- ① Boom operating conditions(fully extended boom length),min. length is 11.8m and max.length is 45m
- ② The span of outriggers is 7.52m×3.1m
- ③ 360°rotation is applied
- ④ Counterweight is 9.5T

Working range(m)	Main boom							Working range(m)
	11.8m	15.95m	20.1m	28.4m	36.7m	40.85m	45m	
3	40000	31000						3
3.5	32000	26000	23000					3.5
4	25500	22000	19500					4
4.5	21000	19000	16500	15800				4.5
5	17900	16000	14000	14000				5
5.5	15000	13700	12000	12400				5.5
6	12800	12000	10600	11000				6
6.5	11000	10500	9400	9600	10000			6.5
7	9600	9100	8200	8600	9000			7
8	7300	6800	6400	7000	7200	7500	7000	8
9	5500	5100	4800	5700	5800	6600	6000	9
10		3900	3400	4600	4800	5600	5000	10
11		3000	2400	3800	4000	4700	4000	11
12		2000	1600	3000	3300	3800	3100	12
14				1700	2100	2600	2000	14
16					1200	1800	1200	16
18						1100		18
Min.elevation angle(°)	/	/	/	47.6	54.6	58	59.6	Min.elevation angle(°)
Number of parts of line	10	8	8	4	3	3	3	Number of parts of line

Prerequisites:

- ① Boom operating conditions(fully extended boom length+jib length), max.length is 45m+9.2m
- ② The span of outriggers is 7.52m×7.4m
- ③ 360°rotation is applied
- ④ Counterweight is 9.5T

Working angle(°)	Main boom+Jib		
	0°	20°	40°
80	5000	4700	3400
79	5000	4700	3400
78	5000	4700	3400
77	5000	4600	3400
76	5000	4500	3300
75	5000	4400	3300
73	5000	4200	3200
70	4700	4100	3100
68	4300	3700	3000
65	3800	3400	2700
63	3300	3000	2300
60	2500	2400	1700
58	2000	2000	1600
55	1500	1500	1300
53	1300	1200	1000
50	1000	900	800

Prerequisites:

- ① Boom operating conditions(fully extended boom length+jib length), max.length is 45m+16m
- ② The span of outriggers is 7.52m×7.4m
- ③ 360°rotation is applied
- ④ Counterweight is 9.5T

Working angle(°)	Main boom+Jib		
	0°	20°	40°
80	3000	2900	2000
79	3000	2800	2000
78	3000	2800	2000
77	3000	2700	1900
76	3000	2700	1900
75	3000	2700	1900
73	3000	2600	1900
70	3000	2500	1900
68	3000	2400	1800
65	2400	2300	1700
63	2200	2200	1700
60	2000	1900	1600
58	1800	1700	1400
55	1500	1400	1000
53			
50			
Min.elevation angle(°)	50	52	52

Prerequisites:

- ① Boom operating conditions(boom length),min. length is 11.8m and max.length is 28.4m
- ② With tyre static lifting load
- ③ 360°rotation is applied
- ④ Counterweight is 9.5T

Working range(m)	Main boom				Working range(m)
	11.8m	15.95m	20.1m	28.4m	
4.5	12000				4.5
5	10000				5
5.5	8900	8600			5.5
6	7600	7400	7200		6
6.5	6300	6400	6300		6.5
7	5200	5000	5400	6200	7
8	3500	3800	3900	4700	8
9	2500	2600	2700	3900	9
10		1700	1800	2900	10
11		900	1000	2200	11
12				1600	12
Min.elevation angle(°)	/	26.5°	49.4°	56.2°	Min.elevation angle(°)
Number of parts of line	6	6	6	6	Number of parts of line

Prerequisites:

- ① Boom operating conditions(boom length),min. length is 11.8m and max.length is 28.4m
- ② With lifting load traveling (boom centered over front)
- ③ Counterweight is 9.5T

Working range(m)	Main boom				Working range(m)
	11.8m	15.95m	20.1m	28.4m	
4	16700				4
4.5	14800				4.5
5	13200				5
5.5	11800	11000			5.5
6	10700	10000	9800		6
6.5	9600	9200	8800		6.5
7	8700	8200	7900	9100	7
8	7100	6700	6300	7500	8
9	5900	5400	5100	6300	9
10		4400	4000	5200	10
11		3500	3100	4300	11
12		2700	2400	3600	12
14			1200	2300	14
16				1400	16
Min.elevation angle(°)	/	/	26.3°	40.1°	Min.elevation angle(°)
Number of parts of line	6	6	6	6	Number of parts of line

1. Values listed in the table refer to rated lifting capacity measured at flat and solid ground under the lever state of the crane.
2. Value above heavy line shall be determined by strength of the crane and under this line shall be determined by stability of the crane.
3. Rated load values determined by stability shall comply with ISO 4305.
4. Rated lifting capacity listed in the table included weights of lifting hooks (810kg of main hook and 160kg of auxiliary hook)and hangers.
5. Rated lifting capacity with pulley at boom tip shall not exceed 6500kg.
6. If actual boom length and range are between two values specified in the table, larger value will determine the lifting capacity.

SRC750 ROUGH-TERRAIN CRANE
WHEEL CRANE FAMILY MAP

TRUCK CRANE



STC200
Maximum Load Capacity: 20t
Telescopic Boom: 4 Sections, 10.6-33m



STC250
Maximum Load Capacity: 25t
Telescopic Boom: 4 Sections, 10.65-33.5m



STC250H
Maximum Load Capacity: 25t
Telescopic Boom: 5 Sections, 10.5-39.5m



STC300TH
Maximum Load Capacity: 30t
Telescopic Boom: 4 Sections, 10.6-33.5m



STC300H
Maximum Load Capacity: 30t
Telescopic Boom: 5 Sections, 10.5-39.5m



STC500
Maximum Load Capacity: 50t
Telescopic Boom: 5 Sections, 11.5-43m



STC550
Maximum Load Capacity: 55t
Telescopic Boom: 5 Sections, 11.5-43m



STC550EYR
Maximum Load Capacity: 55t
Telescopic Boom: 5 Sections, 11.5-43m



STC600
Maximum Load Capacity: 60t
Telescopic Boom: 5 Sections, 11.5-43m



STC750
Maximum Load Capacity: 75t
Telescopic Boom: 5 Sections, 11.8-45m



STC800
Maximum Load Capacity: 80t
Telescopic Boom: 5 Sections, 11.8-45m



STC800EYR
Maximum Load Capacity: 80t
Telescopic Boom: 5 Sections, 11.8-45m



STC1000
Maximum Load Capacity: 100t
Telescopic Boom: 5 Sections, 13.5-52m



STC1000C
Maximum Load Capacity: 100t
Telescopic Boom: 6 Sections, 13.25-60m



STC1300C
Maximum Load Capacity: 130t
Telescopic Boom: 6 Sections, 13.3-60m

ALL TERRAIN CRANE



SAC1800
Maximum Load Capacity: 180t
Telescopic Boom: 6 Sections, 13.5-62m



SAC2200
Maximum Load Capacity: 220t
Telescopic Boom: 6 Sections, 13.5-62m



SAC3000
Maximum Load Capacity: 300t
Telescopic Boom: 7 Sections, 15.4-80m



SAC3500
Maximum Load Capacity: 350t
Telescopic Boom: 6 Sections, 15.2-70m



SAC6000
Maximum Load Capacity: 600t
Telescopic Boom: 7 Sections, 17.1-90m

ROUGH-TERRAIN CRANE



SRC350
Maximum Load Capacity: 35t
Telescopic Boom: 4 Sections, 10-31.5m



SRC550
Maximum Load Capacity: 55t
Telescopic Boom: 4 Sections, 11.25-34.5m



SRC550H
Maximum Load Capacity: 55t
Telescopic Boom: 5 Sections, 11.5-42.5m



SRC750
Maximum Load Capacity: 75t
Telescopic Boom: 5 Sections, 11.8-45m



Quality Changes the World

SANY AUTOMOBILE HOISTING MACHINERY

Address: SANY Industrial Park, Jinzhou Development Zone,
Changsha, Hunan, China.
Service Hotline: 4006098318
Email: crd@sany.com.cn
For more information, please visit: www.sanygroup.com

For our consistent improvement in technology, specifications may change without notice.
The machines illustrated may show optional equipment which can be supplied at additional cost.

Distributed By:

--