

# SRC900C

SANY Rough-Terrain Crane  
90 Tons Lifting Capacity



Main boom length: 12~47m  
Max lifting torque: 2820KN.m  
Max lifting height for main boom : 48.7m  
Max lifting height for jib :64.3m

## Excellent and stable chassis

- ISDe285 30 engine, with multi-mode power output function, has the decreased additional power consumption and improved energy efficiency.
- Real-time 4x4 drive; maximum speed: 35km/h, maximum gradability: 75%; excellent power.
- 4 steering modes; minimum turning diameter: 7.5m, minimum ground clearance: 530mm; excellent performance.

## Super long, strong and sensitive lifting performance

- Length of fully-extended boom: 47m; truss + box-type extended jib: 17.5m; leading the industry.
- Five-section U-shaped boom and double-cylinder rope-arranging telescopic mechanism are stable and efficient.
- Mounting angle of jib is able to achieve the conversion of 0°, 15° and 30°, enhancing the far-away lifting efficiency.

## Efficient, stable, energy-saving and adjustable hydraulic system

- Load feedback, constant-power control piston pump and electric proportional control multi-valve system ensure the control precision and energy efficiency.
- The dual-pump converging/dividing technology achieves the composite brake cylinder, ensuring the smooth operation and efficient inching.

## Stable, advanced and smart electronic control system

- Self-developed SYMC controller and CAN bus technology keep the signal stable; the all-round smart protection torque limiter is arranged, with the accuracy from 0 to 10%; comprehensive logic and interlock control ensures the safe and reliable operation.

## Humanized design

- Control room may face up for 0° ~ 20° to ease the fatigue during the high-altitude lifting operation;
- Hard and spacious ladder, and barrier-free countertop.



## Dimensions

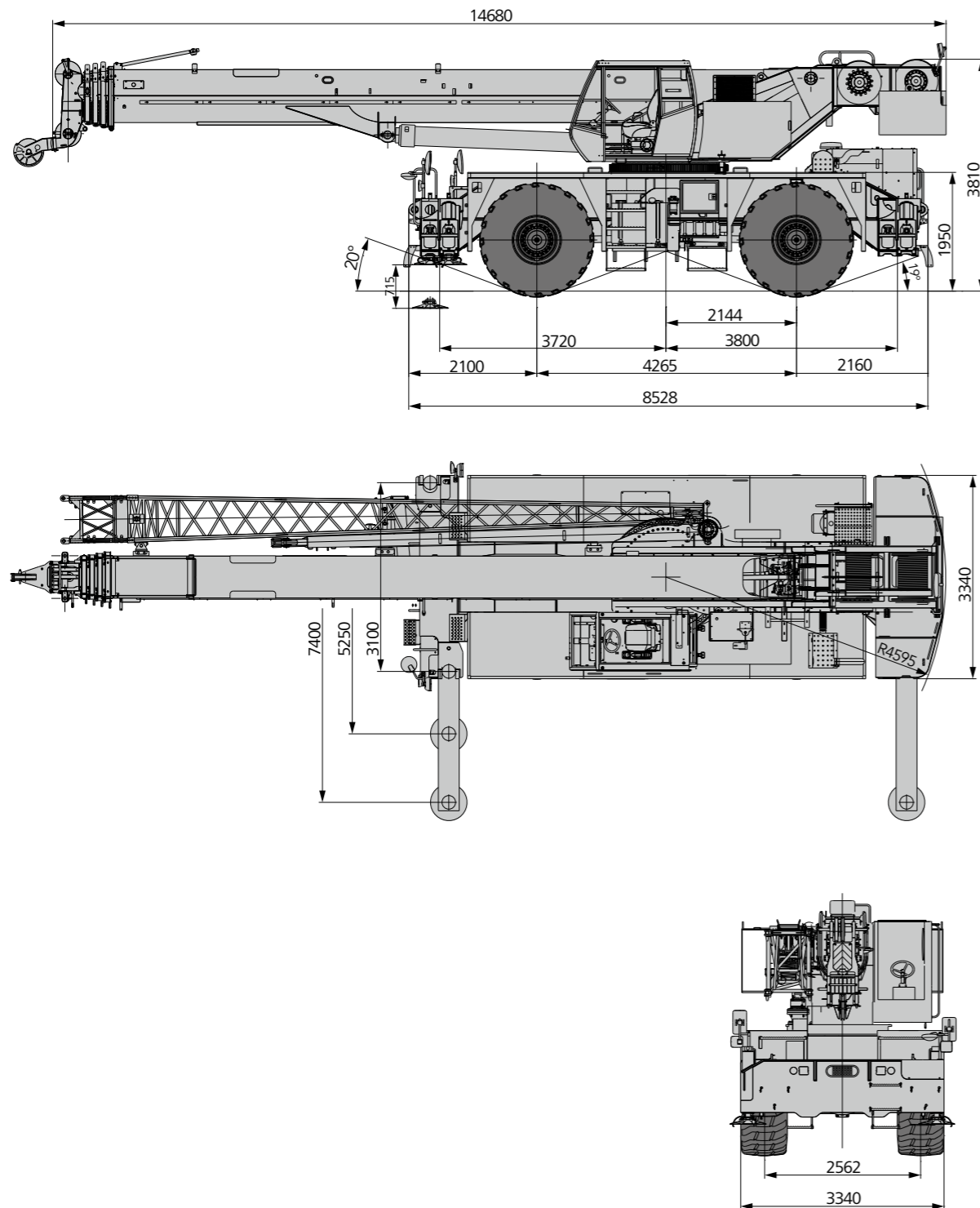

## Technical Parameters

Classification	Item	Unit	Parameter	
Dimension	Overall length	mm	14680	
	Overall width	mm	3340	
	Overall height (without CWT)	mm	3810	
	Axle base	mm	4265	
	Wheel track	mm	2562	
Travelling	Max. travelling speed	km/h	35	
	Min. turning radius (4 wheels)	m	7.5	
	Min. ground clearance	mm	530	
	Approach angle	°	20	
	Departure angle	°	19	
	Max. gradeability	%	75	
Working Speed	Max. lifting speed of single rope of main winch (empty load)	m/min	150	
	Max. lifting speed of single rope of auxiliary winch (empty load)	m/min	150	
	Full extension/retraction time of boom	s	110/125	
	Luffing time of boom	s	90	
	Max. slewing speed	r/min	2	
	Full extension/retraction time of outrigger	s	25/20	
Weight	Overall weight	kg	55000	
	Front axle load	kg	27200	
Power	Rear axle load	kg	27800	
	Engine model	Cummins ISDe285		
	Rated power of engine	kw/rpm	210/2500	
	Rated torque of engine	N.m/rpm	970/1400	
Main Performance Parameters	Emission standard	Stage 3A		
	Max. rated lifting capacity	t	90	
	Min. working radius	m	2.5	
	Max. lifting torque	Base boom	kN.m	2820
		Fully-extended boom	kN.m	1360
	Outrigger span (vertical x longitude)	m	7.52x7.4	
	Max. lifting height	Base boom	m	15.4
		Fully-extended boom	m	48.7
	Boom length	Base boom	m	12.2
		Fully-extended boom	m	47
Fully-extended boom+ jib		m	64.5	
Fitting angle of jib	°	0/15/30		

## Technical Parameters



### Axle Load

Shaft	Front axle	Rear axle	Total weight
Axle load/t	26.6	27.4	54
Note	without main and auxiliary hooks		



### Hook and number of parts of line

Rated load/t	Pulleys	Number of parts of line	Hook weight (kg)
90	6	12	795
50 (Optional)	4	8	595
8	-	1	160

### Standard Equipment

Number	Name	Number	Name
1	Engine	16	Display screen
2	Gear box	17	Controller
3	Torque converter	18	Joy stick
4	Torque converter radiator	19	Film switch
5	Front axle assembly	20	Swing bearing
6	Rear axle assembly	21	Swing reducer
7	Tire	22	Swing motor
8	Rim	23	Hoisting reducer
9	Steering cylinder	24	Hositing motor
10	Steering gear	25	Hoisting balance vlave
11	Piston pump	26	Cable
12	Triple gear pump	27	Hook
13	Main valve	28	Luffing balance vlave
14	Hydraulic radiator	29	Luffing cylinder
15	Battery		

### Option Equipment

- Option hook I (lifting capacity:50t Mass:595kg)
- Option hook II (lifting capacity:30t Mass:360kg)
- Gas pump
- Intake valve
- Winch and backup camera

## Crane Introduction



### Operator's Cab

- The ergonomic design independently developed by SANY, frame-type steel structural body, sliding door, safety glass, corrosion-resistant steel plate, softened interior trim, large interior space, panoramic sunroof, adjustable seats and other user-friendly designs as well as the air conditioning and electric wiper guarantee the more comfortable and easier operation; the torque limiter display achieves the organic combination of console and display system to monitor all the data of operating conditions. Variable-position operator cab, with the maximum raising angle of 20°, ensures the more comfortable operation for the long section operation.



### Hydraulic system

- High-quality and reliable pump, main valve, motor, balance valve and other key hydraulic elements are adopted to ensure the stable and reliable hydraulic system; the operating performance is improved through the accurate parameter matching.
- Load-sensitive variable displacement piston pump is able to conduct the adaptive control for the pump displacement, the high-precision flow control and the accurate control of action, and greatly reduce the energy consumption.
- With the flow compensation and load feedback functions, electric proportional control main valve is able to achieve the stable and accurate control for the single action and combined actions under a variety of operating conditions.
- Winch is equipped with the electronic variable motor, with the high operating efficiency; the maximum single line speed of main and auxiliary winches is up to 135m/min.
- The slewing buffer valve has the free sliding function which ensures the smooth slewing start and control and excellent inching performance. Capacity of hydraulic oil tank: 990L.



### Control system

- Electronic control operating system is provided with the imported electronic control handle and bus connection, with the good control, high reliability and easy maintenance and diagnosis.
- Bus instruments: the bus instruments of integrated smart control electrical system can monitor the driving parameters at any time and facilitate the driving; engine fault prompt function simplifies the maintenance and troubleshooting.
- For the all-round safety protection system, the main and auxiliary winches are provided with the three-wrap rope protector and height limiter to prevent the overfall and overwind of wire rope, plus the anti-tipping protection and extreme angle protection.
- Torque limiter: the highly-smart torque limiter system is used to provide the all-round protection for the lifting operation to ensure the accurate, stable and smooth operation.
- Fault diagnosis system inspects the electrical, hydraulic actions of superstructure, chassis (for major safety faults), engine, gearbox and other faults to ensure the reliable operation of crane.
- Wireless remote control system is adopted to make the assembly and disassembly of overall crane more convenient, safer and more flexible.



### Telescopic boom

- Five sections; base boom: 12.2m; fully-extended boom: 47m; jib: 17.5m, lifting height of fully-extended boom: 48.7m; maximum lifting height with jib: 64.3m; U-shaped and made of high-strength welding structural steel; double-cylinder rope-arranging extension and retraction method.



### Luffing system

- Double-acting single-piston-rod hydraulic cylinder is equipped with the safety balance valve. Self-weight luffing-down system is more energy efficient and improves the smoothness of operation.
- Luffing angle: -2°~78°.



### Slewing

- 360° rotation, double slewing reducer layout, and maximum slewing speed of 2r/min; electric proportional control speed control ensures the stable action and reliable system. Unique slewing buffer design ensures the smooth start and stop, and the excellent control.



### Counterweight

- Removable counterweight is 9500kg, which is easy to disassemble and facilitates the transport of machine.



### Safety device

- Torque limiter: Based on the analytical mechanics method, the torque limiter calculation system based on the lifting force model is established. Through the on-line no-load calibration, the rated lifting accuracy is up to 0-10%, providing the all-round protection for the lifting operation; in case of the overload operation, the system automatically gives alarm to provide the protection for the control operation.
- Hydraulic system is equipped with the hydraulically balanced valve, overflow valve and two-way hydraulic lock etc., to ensure stable and reliable operation.
- Main and auxiliary winches are equipped with three-wrap rope protector to prevent the overfall of wire rope.
- Boom and jib ends are equipped with height limiters respectively to prevent the overwind of wire rope.

## Crane Introduction

### Hoisting

- Pump and motor are of dual variable speed, with the wide speed regulation range and high energy efficiency.
- Winch balance valve is perfectly combined with the unique anti-slip hook technology to ensure the smooth rising and falling processes of weight.
- Anti-rotation high-strength wire rope is provided to accurately locate the lifting.
- Normally-closed winch brake and winch balance valve prevent the loss of weight during the falling process.
- One optional large hook: 795Kg, one optional main hook: 595Kg, and one optional auxiliary hook: 160Kg.
- Main winch wire rope: diameter of 20mm and length of 250m.
- Auxiliary winch wire rope: diameter of 20mm and length of 145m.

### Frame

- Frame is welded with the high-strength steel plates, with the strong carrying capacity.

### Outrigger

- H-shaped outrigger, 4-point support, vertical/horizontal span of 7.52m×7.4m.
- Fine grain high-strength steel plate, and the vertical cylinder protected with the two-way hydraulic lock.

### Engine

- Type: In-line six-cylinder, water cooling, supercharged and mid-cooling, diesel engine.
- Rated power: 210kw/2500r/min.
- Environmental protection: Emissions as per Stage 3A standard.
- Effective volume of fuel tank: 350L.

### Transmission

- Torque converter/gearbox: automatic transmission, with 6 gears; the large speed ratio range applies to the low-speed climbing and the high-speed driving.
- Drive shaft: the optimized drive shaft layout ensures the smooth and reliable drive operation.

### Drive/steering

- 4x4 drive, full hydraulic power steering, with four modes such as front wheel steering, rear wheel steering, four wheel steering and crab steering.

### Axle

- Front and rear axles are the steering drive shafts.

### Tyre

- 4\*—29.5R25 ★★ ★ .

### Brake system

- Double-circuit braking system is adopted where one circuit still works properly when the other fails, and the safety and reliability of braking system are improved.
- Service brake is equipped with the double-circuit braking system where the independent circuit brake is provided for the front and rear axles, and all wheels are equipped with disc brakes.
- Parking brake is a disc brake on the front axle flange.

### Electric system

- 2\*12V maintenance-free battery is provided with the mechanical power switch, and the overall power may be manually cut off.

## Lifting Heights

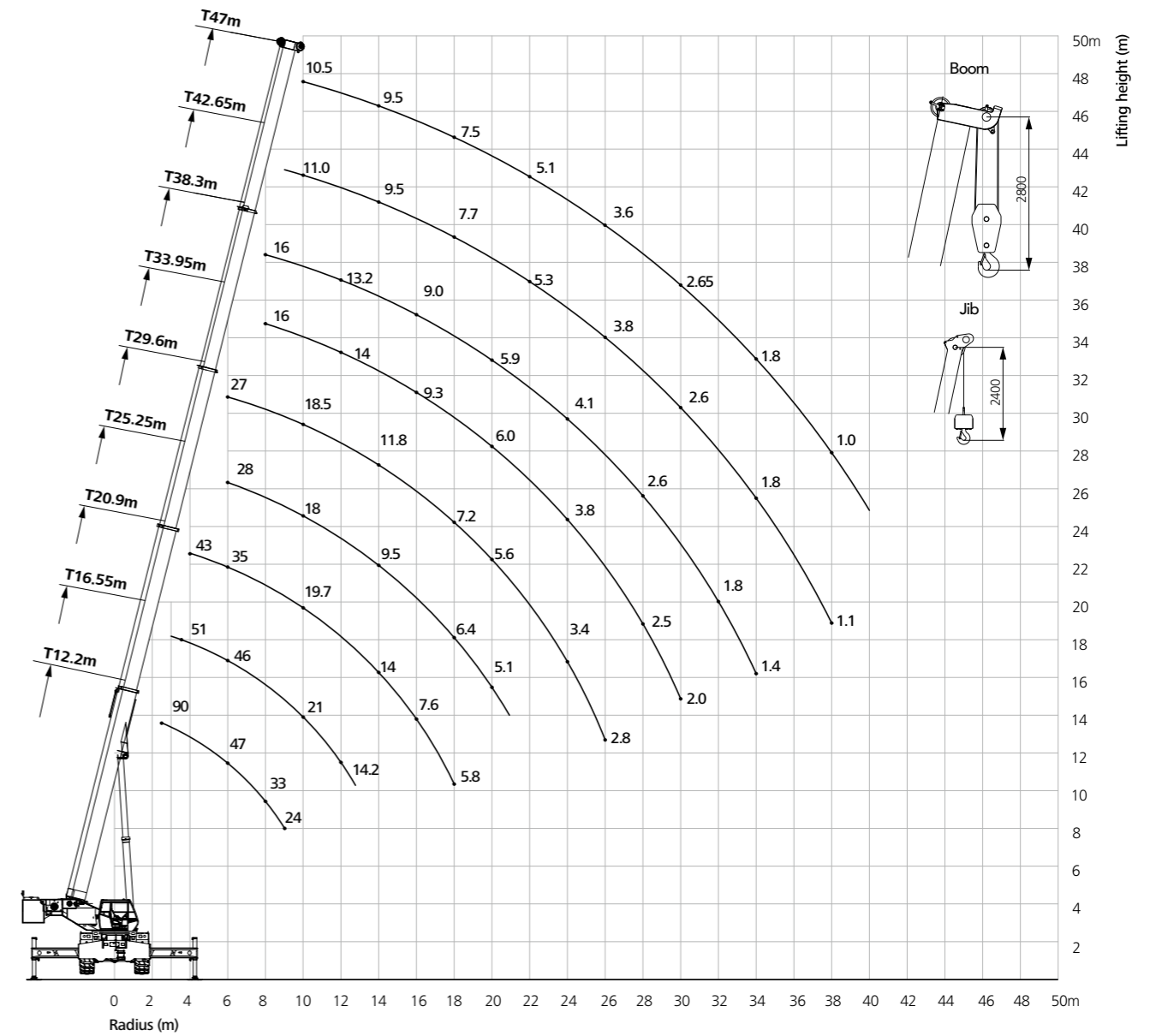

### Lifting Capacity

Unit: t

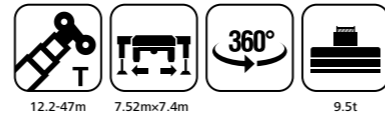

Radius (m)	SRC900C, outriggers fully extended, 360, CW 9,5 t												Radius (m)
	12.20	16.55		20.90		25.25		29.60					
2.5	90.00												2.5
3.0	80.00	51.00	28.00										3.0
3.5	75.00	51.00	28.00										3.5
4.0	67.00	51.00	28.00	43.00	28.00	28.00							4.0
4.5	62.00	49.00	28.00	41.00	27.50	27.00							4.5
5.0	56.50	48.00	28.00	39.00	27.00	25.00	28.00	26.00	25.00				5.0
5.5	52.00	47.00	28.00	37.00	25.20	23.50	28.00	24.80	23.50	27.00	23.50	16.00	5.5
6.0	47.00	46.00	28.00	35.00	23.80	22.20	28.00	23.50	22.20	27.00	23.50	16.00	6.0
6.5	43.50	42.00	28.00	33.30	23.00	21.00	28.00	23.00	21.00	26.00	22.50	16.00	6.5
7.0	39.50	39.50	27.70	31.80	22.30	19.80	28.00	21.80	19.80	24.60	21.20	15.20	7.0
8.0	33.00	32.00	27.20	28.00	20.90	17.50	23.00	20.50	17.50	22.00	20.70	14.80	8.0
9.0	24.00	24.50	24.50	23.30	18.00	16.30	21.00	18.00	16.30	20.00	18.10	13.60	9.0
10.0		21.00	21.00	19.70	17.00	15.50	18.00	17.20	14.00	18.50	17.20	11.80	10.0
11.0		17.00	17.10	17.00	16.00	14.00	14.80	16.60	12.60	16.50	16.40	10.60	11.0
12.0		14.20	14.50	14.00	12.80	12.00	11.70	13.90	11.20	14.50	14.00	9.50	12.0
14.0				10.20	10.20	10.50	9.50	10.40	10.20	11.90	10.80	8.60	14.0
16.0				7.60	7.60	7.60	8.00	8.40	8.70	9.30	8.60	7.00	16.0
18.0				5.80	5.80	5.80	6.40	6.60	6.90	7.20	6.90	6.10	18.0
20.0							5.10	5.30	5.50	5.65	5.70	5.40	20.0
22.0										4.40	4.50	4.65	22.0
24.0										3.40	3.70	3.85	24.0
26.0										2.80	2.90	3.20	26.0
28.0													28.0
30.0													30.0
32.0													32.0
34.0													34.0
36.0													36.0
38.0													38.0
Part Line	12	10	8	8	8	6	6	6	6	6	5	5	Part Line
Mode	I,II	I	II	I	I,II	II	I,II	I,II	II	I,II	I,II	II	Mode
TELE1	0%	50%	0%	100%	50%	0%	100%	50%	0%	100%	50%	0%	TELE1
TELE2	0%	0%	17%	0%	17%	33%	17%	33%	50%	33%	50%	66%	TELE2
TELE3	0%	0%	17%	0%	17%	33%	17%	33%	50%	33%	50%	66%	TELE3
TELE4	0%	0%	17%	0%	17%	33%	17%	33%	50%	33%	50%	66%	TELE4
Min Boom Angle	/	/	/	/	/	/	/	/	/	/	/	/	Min Boom Angle
Capacity at 0° Boom Angle	13.25	8.00	8.20	4.00	4.40	5.20	2.50	2.70	3.30	1.50	1.80	2.10	Capacity at 0° Boom Angle

### Lifting Capacity

Unit: t

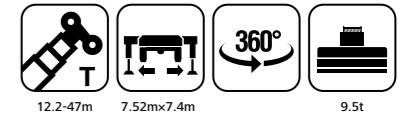

Radius (m)	SRC900C, outriggers fully extended, 360, CW 9,5 t									Radius (m)
	33.95			38.30			42.70		47.00	
2.5										2.5
3.0										3.0
3.5										3.5
4.0										4.0
4.5										4.5
5.0										5.0
5.5										5.5
6.0										6.0
6.5	16.00	16.00	10.50							6.5
7.0	16.00	16.00	10.50	16.00	15.50	10.00				7.0
8.0	16.00	16.00	10.50	16.00	14.90	9.50				8.0
9.0	16.00	16.00	10.00	16.00	14.50	9.10	11.00	10.50		9.0
10.0	16.00	15.80	9.80	15.50	14.00	8.90	11.00	10.50	10.50	10.0
11.0	15.20	15.20	9.40	14.20	13.00	8.70	11.00	10.00	10.50	11.0
12.0	14.00	14.10	9.10	13.20	12.20	8.40	10.50	9.70	10.00	12.0
14.0	11.50	11.30	8.70	11.20	10.10	7.50	9.50	9.30	9.50	14.0
16.0	9.30	8.80	6.70	9.20	8.80	5.40	8.50	8.00	8.50	16.0
18.0	7.50	7.50	5.40	7.40	6.95	4.50	7.70	6.90	7.60	18.0
20.0	6.00	6.05	4.50	6.10	6.10	4.20	6.60	5.90	6.50	20.0
22.0	5.00	5.00	3.90	5.10	5.10	3.90	5.50	5.05	5.30	22.0
24.0	3.80	4.05	3.70	4.20	4.20	3.70	4.60	4.25	4.20	24.0
26.0	3.10	3.30	3.30	3.40	3.55	3.50	3.90	3.80	3.60	26.0
28.0	2.50	2.65	2.80	2.80	2.80	3.10	3.20	3.30	3.10	28.0
30.0	2.00	2.15	2.30	2.30	2.35	2.65	2.70	2.90	2.65	30.0
32.0				1.80	1.95	2.25	2.30	2.45	2.20	32.0
34.0				1.40	1.60	1.90	1.80	2.05	1.75	34.0
36.0							1.40	1.70	1.35	36.0
38.0							1.10	1.35	1.05	38.0
Part Line	5	4	4	4	4	4	3	3	3	Part Line
Mode	I,II	I,II	II	I,II	I,II	II	I,II	I,II	I,II	Mode
TELE1	100%	50%	0%	100%	50%	0%	100%	50%	100%	TELE1
TELE2	50%	66%	84%	66%	84%	100%	84%	100%	100%	TELE2
TELE3	50%	66%	84%	66%	84%	100%	84%	100%	100%	TELE3
TELE4	50%	66%	84%	66%	84%	100%	84%	100%	100%	TELE4
Min Boom Angle	/	/	/	/	/	/	(19.0)	(17.0)	(22.0)	Min Boom Angle
Capacity at 0° Boom Angle	0.90	1.30	1.70	0.40	0.55	0.75	/	/	/	Capacity at 0° Boom Angle

### Load Chart - Telescopic Boom

Unit: t

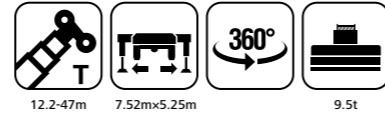

Radius (m)	SRC900C, outriggers half extended, 360, CW 9,5 t												Radius (m)
	12.20	16.55		20.90		25.25		29.60					
3.0	75.00	48.00	28.00										3.0
3.5	68.00	48.00	28.00										3.5
4.0	61.00	48.00	28.00	43.00	26.00	20.00							4.0
4.5	53.00	48.00	28.00	41.00	26.00	20.00							4.5
5.0	48.00	42.00	28.00	38.00	26.00	20.00	26.00	22.00	18.00				5.0
5.5	41.00	36.50	28.00	32.50	25.20	20.00	26.00	22.00	18.00	24.00	22.00	16.00	5.5
6.0	36.00	31.60	28.00	28.50	23.80	20.00	24.00	22.00	18.00	24.00	22.00	16.00	6.0
6.5	31.00	28.00	26.00	25.20	22.60	20.00	22.00	22.00	18.00	22.00	19.00	16.00	6.5
7.0	26.00	24.70	24.70	22.20	21.00	19.80	20.00	20.00	18.00	20.00	18.00	16.00	7.0
8.0	20.00	19.60	19.60	18.10	17.80	17.50	17.50	18.00	16.00	18.00	16.75	15.50	8.0
9.0	15.80	15.50	15.50	15.00	15.50	16.30	15.20	15.10	15.00	15.00	15.00	15.00	9.0
10.0		12.50	12.50	13.40	13.40	14.20	12.80	13.20	13.60	12.80	13.80	14.80	10.0
11.0		10.20	10.20	9.80	10.85	11.90	10.60	11.60	12.60	11.00	12.00	13.00	11.0
12.0		8.20	8.50	8.10	9.40	10.10	8.70	9.80	11.00	9.50	10.40	11.30	12.0
14.0				5.50	6.90	7.50	6.20	7.20	8.30	6.90	7.75	8.60	14.0
16.0				3.70	5.10	5.60	4.40	5.50	6.40	5.10	5.90	6.70	16.0
18.0				2.50	3.60	4.20	3.10	4.00	5.00	3.70	4.50	5.30	18.0
20.0							2.10	3.00	3.90	2.65	3.43	4.20	20.0
22.0										1.95	2.65	3.35	22.0
24.0										1.30	1.95	2.60	24.0
26.0											1.45	2.00	26.0
28.0													28.0
30.0													30.0
Part Line	12	8	6	8	8	6	6	6	4	5	5	5	Part Line
Mode	I,II	I	II	I	I,II	II	I,II	I,II	II	I,II	I,II	II	Mode
TELE1	0%	50%	0%	100%	50%	0%	100%	50%	0%	100%	50%	0%	TELE1
TELE2	0%	0%	17%	0%	17%	33%	17%	33%	50%	33%	50%	66%	TELE2
TELE3	0%	0%	17%	0%	17%	33%	17%	33%	50%	33%	50%	66%	TELE3
TELE4	0%	0%	17%	0%	17%	33%	17%	33%	50%	33%	50%	66%	TELE4
Min Boom Angle	/	/	/	/	/	/	/	/	/	(10.0)	(10.0)	(10.0)	Min Boom Angle
Capacity at 0° Boom Angle	12.90	5.80	7.00	2.25	2.70	4.40	1.30	1.80	2.40	/	/	/	Capacity at 0° Boom Angle

### Load Chart - Telescopic Boom

Unit: t

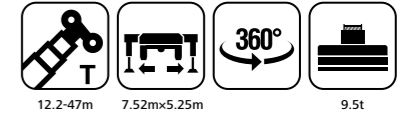

Radius (m)	SRC900C, outriggers half extended, 360, CW 9,5 t										Radius (m)
	33.95		38.30		42.70		47.00				
3.0											3.0
3.5											3.5
4.0											4.0
4.5											4.5
5.0											5.0
5.5											5.5
6.0											6.0
6.5	20.00	16.00	10.50	16.00	14.50						6.5
7.0	19.00	16.00	10.50	16.00	13.50	11.00					7.0
8.0	17.00	16.00	10.50	16.00	13.50	11.00					8.0
9.0	15.00	16.00	10.00	14.20	12.60	11.00	11.00	10.50			9.0
10.0	13.00	14.20	9.80	12.30	11.40	10.50	11.00	10.50	9.50		10.0
11.0	11.00	12.20	9.40	10.80	10.40	10.00	10.70	10.00	9.50		11.0
12.0	9.60	10.80	9.00	9.50	9.50	9.50	9.90	9.50	9.10		12.0
14.0	7.20	8.10	8.50	7.50	8.10	8.80	8.00	8.30	7.60		14.0
16.0	5.20	6.20	6.70	5.80	6.30	6.90	6.20	6.50	5.80		16.0
18.0	3.80	4.80	5.30	4.40	5.00	5.50	5.00	5.20	4.60		18.0
20.0	2.70	3.75	4.20	3.30	4.00	4.40	4.00	4.20	3.60		20.0
22.0	2.10	2.90	3.35	2.45	3.10	3.60	3.10	3.30	2.90		22.0
24.0	1.60	2.30	2.70	1.80	2.40	2.85	2.40	2.55	2.25		24.0
26.0	1.20	1.80	2.15	1.40	1.85	2.30	1.80	1.95	1.70		26.0
28.0				1.00	1.50	1.85	1.30	1.50	1.30		28.0
30.0					1.10	1.45	0.85	1.10			30.0
Part Line	4	4	4	4	4	3	3	3	3	Part Line	
Mode	I,II	I,II	II	I,II	I,II	II	I,II	I,II	I,II	Mode	
TELE1	100%	50%	0%	100%	50%	0%	100%	50%	100%	TELE1	
TELE2	50%	66%	84%	66%	84%	100%	84%	100%	100%	TELE2	
TELE3	50%	66%	84%	66%	84%	100%	84%	100%	100%	TELE3	
TELE4	50%	66%	84%	66%	84%	100%	84%	100%	100%	TELE4	
Min Boom Angle	(30.0)	(23.0)	(21.0)	(32.0)	(27.0)	(26.0)	(38.0)	(32.0)	(40.0)	Min Boom Angle	
Capacity at 0° Boom Angle	/	/	/	/	/	/	/	/	/	Capacity at 0° Boom Angle	

### Load Chart - Telescopic Boom

Unit: t

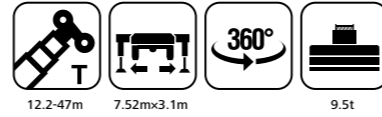

Radius (m)	SRC900C, outriggers full retracted, 360, CW 9,5 t												Radius (m)
	12.20	16.55		20.90			25.25			29.60			
3.0	40.00	31.00	25.00										3.0
3.5	32.00	26.00	23.00	23.00									3.5
4.0	25.50	22.00	21.50	20.00	20.00	20.00							4.0
4.5	21.00	19.00	18.00	16.50	16.50	16.50							4.5
5.0	17.90	16.00	15.20	14.00	14.00	14.00	16.00	16.00	16.00	14.00	14.00	14.00	5.0
5.5	15.00	13.70	13.20	12.00	12.50	13.00	14.00	14.50	14.50	12.50	12.50	12.50	5.5
6.0	12.80	12.00	11.50	10.60	10.80	11.20	12.50	12.80	12.80	11.00	11.50	12.00	6.0
6.5	11.00	10.50	10.20	9.40	9.90	10.50	11.00	11.50	11.50	9.60	10.40	11.20	6.5
7.0	9.60	9.10	9.10	8.20	8.70	9.00	9.90	10.50	10.50	8.60	9.40	10.20	7.0
8.0	7.30	6.80	7.00	6.30	6.70	7.10	8.00	8.30	8.50	7.00	8.00	9.00	8.0
9.0	5.50	5.20	5.50	4.70	5.20	5.60	6.30	6.70	7.20	5.70	7.00	7.40	9.0
10.0		3.90	4.60	3.40	4.00	4.40	5.00	5.50	6.00	4.60	5.80	6.20	10.0
11.0		3.00	3.70	2.50	3.10	3.50	4.00	4.50	5.00	3.80	4.80	5.20	11.0
12.0		2.20	3.00	1.85	2.30	2.80	3.20	3.60	4.00	3.10	4.00	4.40	12.0
14.0							2.00	2.40	2.80	1.80	2.80	3.20	14.0
16.0							1.00	1.60	2.00		1.90	2.30	16.0
18.0											1.20	1.60	18.0
Part Line	8	6	6	6	4	4	4	4	4	4	4	4	Part Line
Mode	I,II	I	II	I	I,II	II	I,II	I,II	II	I,II	I,II	II	Mode
TELE1	0%	50%	0%	100%	50%	0%	100%	50%	0%	100%	50%	0%	TELE1
TELE2	0%	0%	17%	0%	17%	33%	17%	33%	50%	33%	50%	66%	TELE2
TELE3	0%	0%	17%	0%	17%	33%	17%	33%	50%	33%	50%	66%	TELE3
TELE4	0%	0%	17%	0%	17%	33%	17%	33%	50%	33%	50%	66%	TELE4
Min Boom Angle	0.0	(10.0)	(10.0)	(28.0)	(20.0)	(15.0)	(41.0)	(36.0)	(33.0)	(46.0)	(42.0)	(40.0)	Min Boom Angle
Capacity at 0° Boom Angle	/	/	/	/	/	/	/	/	/	/	/	/	Capacity at 0° Boom Angle

### Load Chart - Telescopic Boom

Unit: t

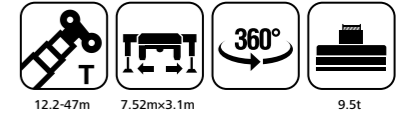

Radius (m)	SRC900C, outriggers full retracted, 360, CW 9,5 t										Radius (m)
	33.95			38.30			42.70		47.00		
3.0											3.0
3.5											3.5
4.0											4.0
4.5											4.5
5.0											5.0
5.5											5.5
6.0											6.0
6.5	11.00	10.50	10.50								6.5
7.0	10.00	9.90	10.50	9.00	9.00	9.00					7.0
8.0	8.50	8.20	9.00	7.20	7.60	8.00					8.0
9.0	6.90	7.20	7.50	5.80	6.35	6.90	6.60	6.50	6.00		9.0
10.0	5.40	6.00	6.30	4.80	5.40	6.00	5.60	5.60	5.00		10.0
11.0	4.50	5.00	5.30	4.00	4.65	5.30	4.70	4.80	4.00		11.0
12.0	3.60	4.20	4.50	3.30	3.95	4.60	3.80	4.20	3.10		12.0
14.0	2.40	3.00	3.40	2.10	2.90	3.50	2.60	2.80	2.00		14.0
16.0	1.50	2.10	2.40	1.20	2.10	2.50	1.80	2.00	1.20		16.0
18.0		1.50	1.70		1.50	1.80	1.10	1.40			18.0
Part Line	3	3	3	3	3	3	3	3	3	Part Line	
Mode	I,II	I,II	II	I,II	I,II	II	I,II	I,II	I,II	Mode	
TELE1	100%	50%	0%	100%	50%	0%	100%	50%	100%	TELE1	
TELE2	50%	66%	84%	66%	84%	100%	84%	100%	100%	TELE2	
TELE3	50%	66%	84%	66%	84%	100%	84%	100%	100%	TELE3	
TELE4	50%	66%	84%	66%	84%	100%	84%	100%	100%	TELE4	
Min Boom Angle	(49.0)	(46.0)	(42.0)	(53.0)	(50.0)	(48.0)	(55.0)	(54.0)	(58.0)	Min Boom Angle	
Capacity at 0° Boom Angle	/	/	/	/	/	/	/	/	/	Capacity at 0° Boom Angle	



### Jib Operating Range

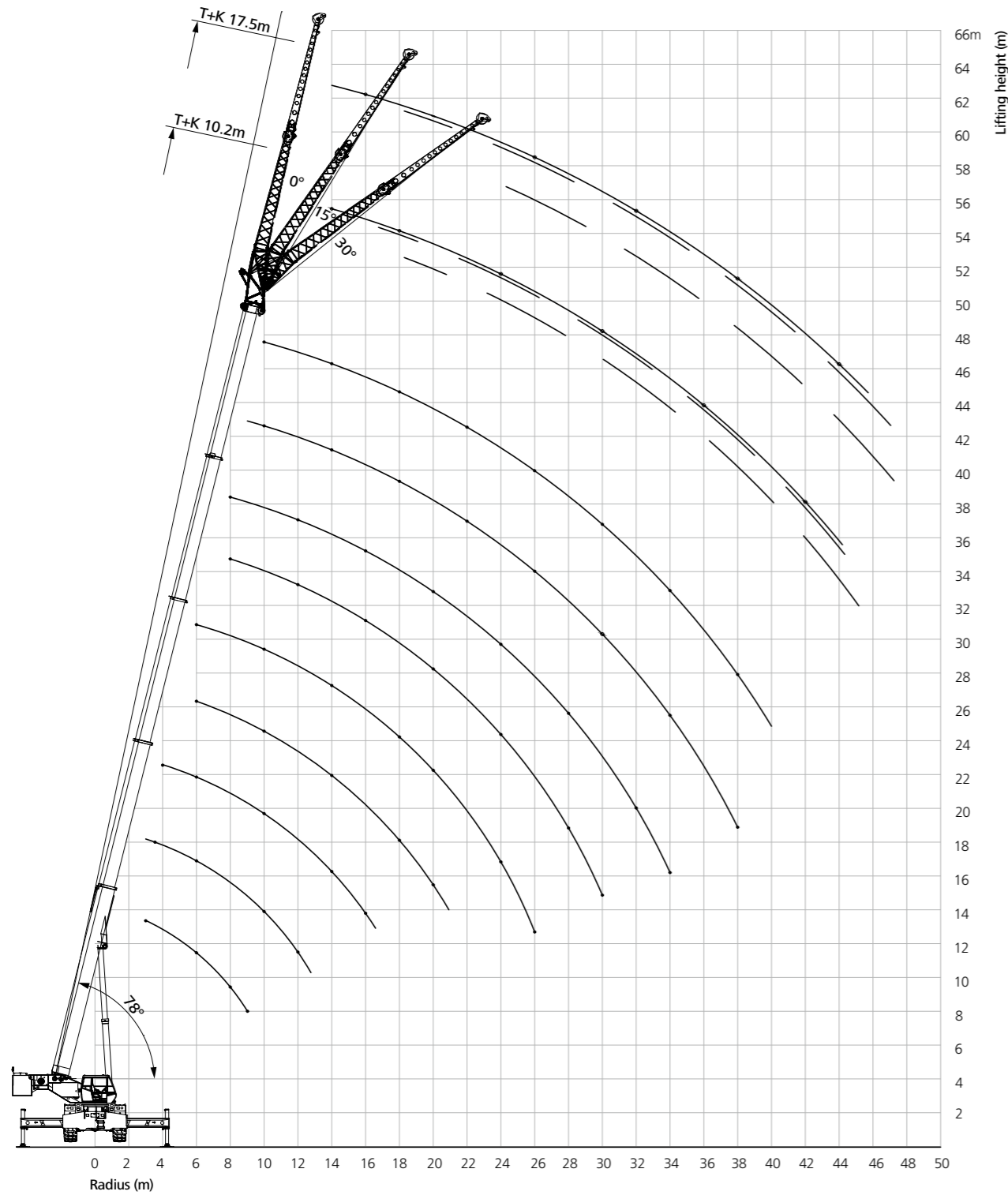

### Load Chart - Fixed Jib

Unit: t

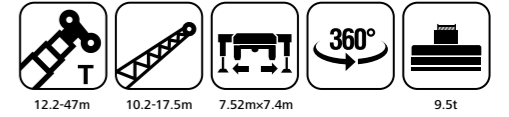

Working length of the boom	Main boom, outriggers fully extended, 360, CW 9.5 t												Working length of the boom
	Main boom 47,0 m + Jib 10,2 m						Main boom 47,0 m + Jib 17,5 m						
	0°		15°		30°		0°		15°		30°		
	main boom operating elevation (°)	lifting weight	main boom operating elevation (°)	lifting weight	main boom operating elevation (°)	lifting weight	main boom operating elevation (°)	lifting weight	main boom operating elevation (°)	lifting weight	main boom operating elevation (°)	lifting weight	
10	77.6	6.50											10
11	76.5	6.50					78.1	3.80					11
12	75.5	6.50	78.0	5.00			77.2	3.65					12
14	73.4	6.20	75.9	4.80	78.2	4.40	75.3	3.30					14
16	71.3	5.80	73.8	4.60	76.0	4.30	73.5	3.00	77.4	2.50			16
18	69.7	5.40	72.1	4.30	74.4	4.20	72.1	2.85	76.0	2.50			18
20	67.5	5.00	70.0	4.10	72.1	4.10	70.2	2.75	74.1	2.40	77.8	2.00	20
22	65.3	4.30	67.7	3.80	69.9	3.90	68.3	2.65	72.2	2.30	75.8	2.00	22
24	63.1	3.70	65.5	3.60	67.6	3.65	66.4	2.55	70.2	2.20	73.8	2.00	24
26	61.3	3.10	63.7	3.20	65.8	3.30	64.9	2.40	68.8	2.10	72.3	1.95	26
28	59.0	2.50	61.4	2.75	63.4	2.85	63.0	2.20	66.7	2.00	70.2	1.85	28
30	56.6	2.00	58.9	2.30	60.9	2.50	60.9	2.00	64.7	1.90	68.1	1.70	30
32	54.1	1.60	56.5	1.85	58.4	2.15	58.8	1.80	62.6	1.80	66.0	1.55	32
34	52.1	1.20	54.4	1.30	56.2	1.60	57.2	1.60	61.0	1.65	64.2	1.45	34
36	49.4	1.00	51.7	1.05	53.5	1.10	55.0	1.40	58.7	1.55	62.0	1.30	36
38					50.6	0.70	52.8	1.05	56.5	1.40	59.6	1.20	38
40									54.1	1.10	57.2	1.10	40
42											54.7	1.00	42
Part Line	1	1	1	1	1	1	1	1	1	1	1	1	Part Line
Min Angle(°)	37		38		40		43		45		47		Min Angle(°)

### Jib Operating Range

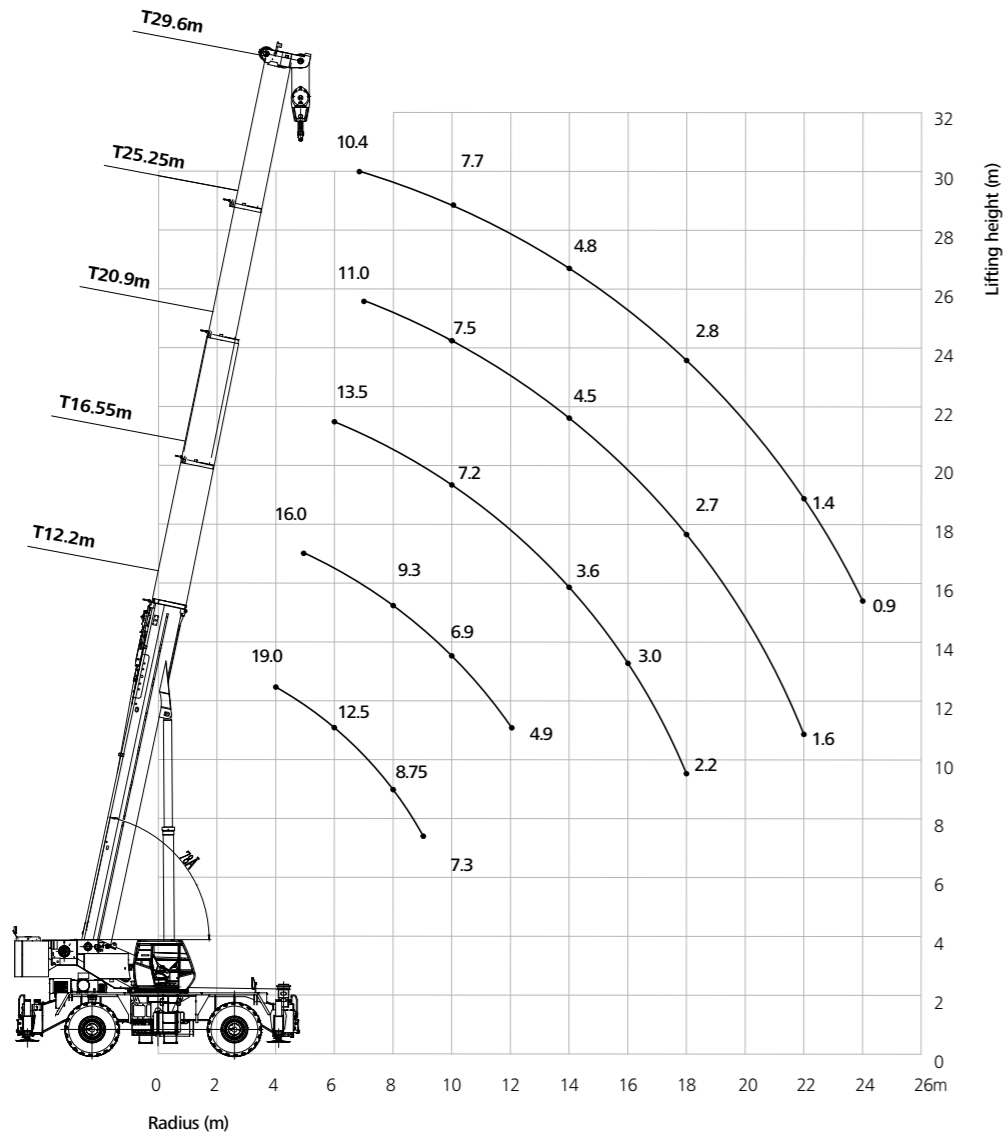

### Load Chart - Telescopic Boom

Unit: t

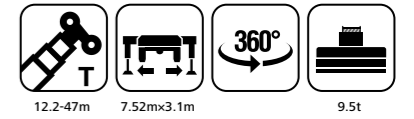

Radius (m)	Sany SRC900C Pick & Carry					Radius (m)
	12.2	16.55	20.9	25.25	29.6	
4.0	19.00					4.0
4.5	17.00					4.5
5.0	15.30	16.00				5.0
5.5	13.80	14.00				5.5
6.0	12.50	13.10	13.50			6.0
6.5	11.50	12.00	12.30			6.5
7.0	10.40	11.00	11.40	11.00	10.40	7.0
8.0	8.75	9.30	9.70	9.90	10.00	8.0
9.0	7.30	8.10	8.50	8.60	8.70	9.0
10.0		6.90	7.20	7.50	7.70	10.0
11.0		5.70	6.10	6.50	6.80	11.0
12.0		4.90	5.30	5.80	6.20	12.0
14.0			3.60	4.50	4.80	14.0
16.0			3.00	3.70	3.80	16.0
18.0			2.20	2.70	2.80	18.0
20.0				2.00	2.10	20.0
22.0				1.60	1.40	22.0
24.0					0.90	24.0
Mode	I,II	II	II	II	II	Mode
2nd	0	0	0	0	0	2nd
3rd	0	17.5	33	50	66	3rd
4th	0	17.5	33	50	66	4th
top	0	17.5	33	50	66	top
Min Boom Angle	0°	0°	30°	36°	43°	Min Boom Angle
Part Line	4	4	4	3	3	Part Line

### Jib Operating Range

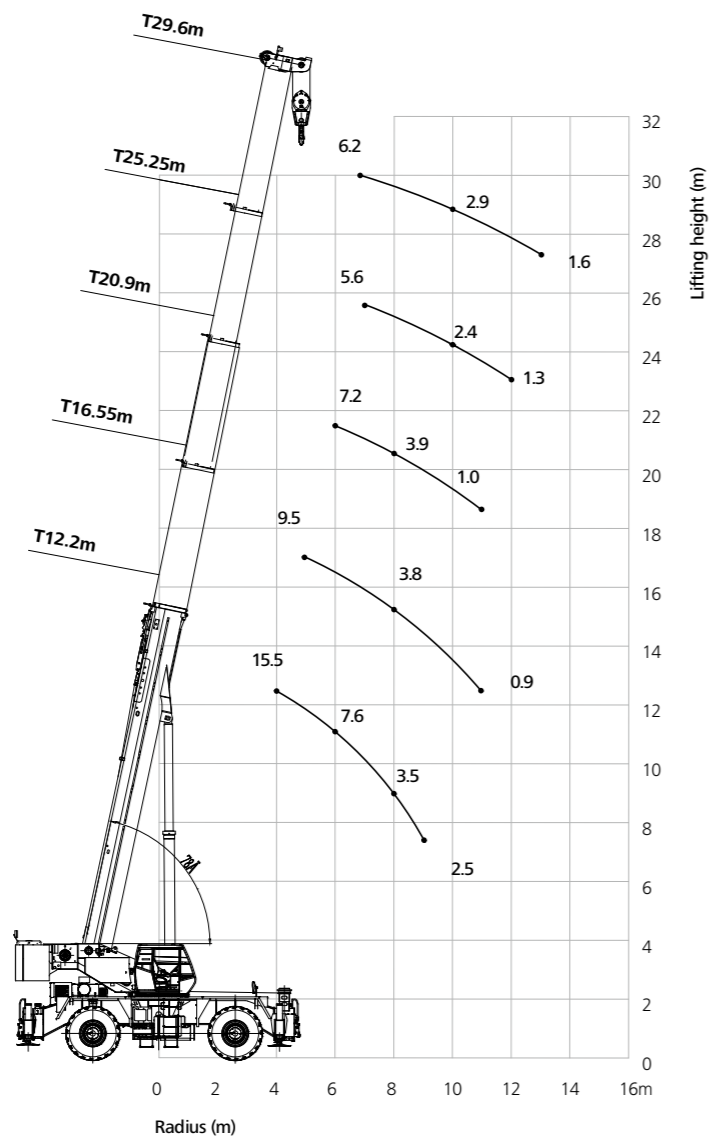

### Load Chart - Telescopic Boom



Unit: t

Radius (m)	Sany SRC900C Load Stationary, On Tires, 360°					Radius (m)
	12.2	16.55	20.9	25.25	29.6	
4.0	15.50					4.0
4.5	12.90					4.5
5.0	9.70	9.50				5.0
5.5	8.90	8.60	9.00			5.5
6.0	7.60	7.40	7.20			6.0
6.5	6.30	6.40	6.30	6.80		6.5
7.0	5.20	5.00	5.40	5.60	6.20	7.0
8.0	3.50	3.80	3.90	4.30	4.70	8.0
9.0	2.50	2.60	2.70	3.30	3.90	9.0
10.0		1.70	1.80	2.40	2.90	10.0
11.0		0.90	1.00	1.80	2.20	11.0
12.0				1.30	1.60	12.0
14.0					0.90	14.0
Mode	I,II	II	II	II	II	Mode
2nd	0	0	0	0	0	2nd
3rd	0	17.5	33	50	66	3rd
4th	0	17.5	33	50	66	4th
top	0	17.5	33	50	66	top
Min Boom Angle	0°	30°	46°	48°	51°	Min Boom Angle
Part Line	6	4	4	4	4	Part Line

The load capacity is calibrated by angle when the main boom is less than 43m, otherwise is calibrated by working radius

## Notes



## Sany Automobile Hoisting Machinery Co., Ltd.

No.168, Jinzhou Avenue, Jinzhou Development Zone, Changsha, Hunan, China

Postcode: 410600

Service: 0086-400 6098 318 Consulting: 400 8879 318

Email: crd@sany.com.cn

— Authorised Dealer —

### Reminder:

For safe and reliable operation of the diesel engines, please fill Grade IV machines with Grade IV diesel and urea solution conforming to related national standards. Please refer to the operating instructions and related standards for details.

Any change in the technical parameters and configuration due to advancement in technology may occur without prior notice. The machine in the figures may include auxiliary equipment. This brochure is for reference only, and goods in kind shall prevail.

Copyright at Sany Heavy Industry. No part of this catalogue may be copied, recorded or used for any purpose without written approval from Sany Heavy Industry.

© Printed in November 2018 in China

[www.sanyglobal.com](http://www.sanyglobal.com)

